

I G	1 1a	2 2a	3 3a	4 4a	5 5a	6 6a	7 7a	8 8a
⌋		X		X	X			X
0								
120	X			X		X	X	X
⌋	X		X	X		X	X	X

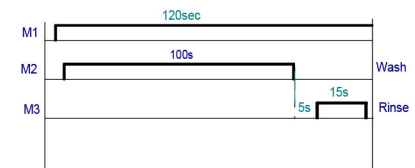

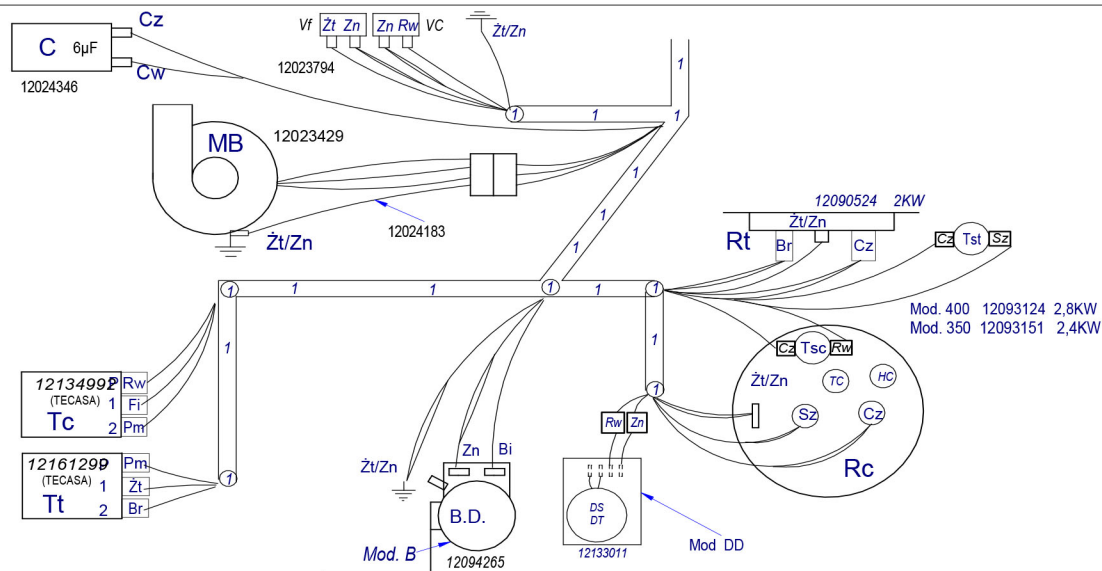

	Polski KOLOR	КОЛОР	Angielski COLOUR	Hiszpański COLORES
	Czarny Cz	Чорний Cz	Black bk	Negro n
	Niebieski Nb	Синий Nb	Blue bl	Azul a
	Brązowy Br	Коричневий Br	Brown bn	Marron m
	Zielony Zn	Зелений Zn	Green gn	Verde ve
	Szary Sz	Сірий Sz	Grey gy	Gris g
	Pomarańcz Pm	Помаранчевий Pm	Orange or	Naranja na
	Różowy Rw	Рожевий Rw	Pink pk	Rosa rs
	Fioletowy Fi	Фіолетовий Fi	Purple pr	Violeta vi
	Czerwony Cw	Червоний Cw	Red rd	Rojo r
	Biały Bi	Білий Bi	White wh	Blanco b
	Zółty Zt	Жовтий Zt	Yellow yw	Amarillo am
	/Zielony Zt/Zn	/Жовтий / Зелений Zt/Zn	/Yellow /green am/ve	/Amarillo /verde am/ve

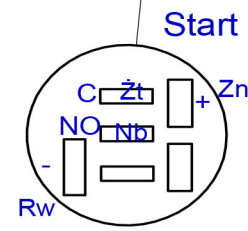
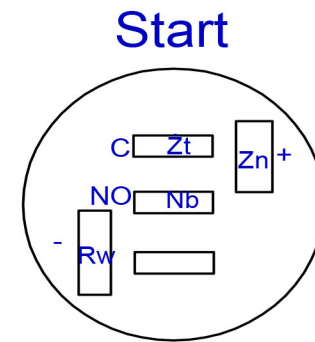
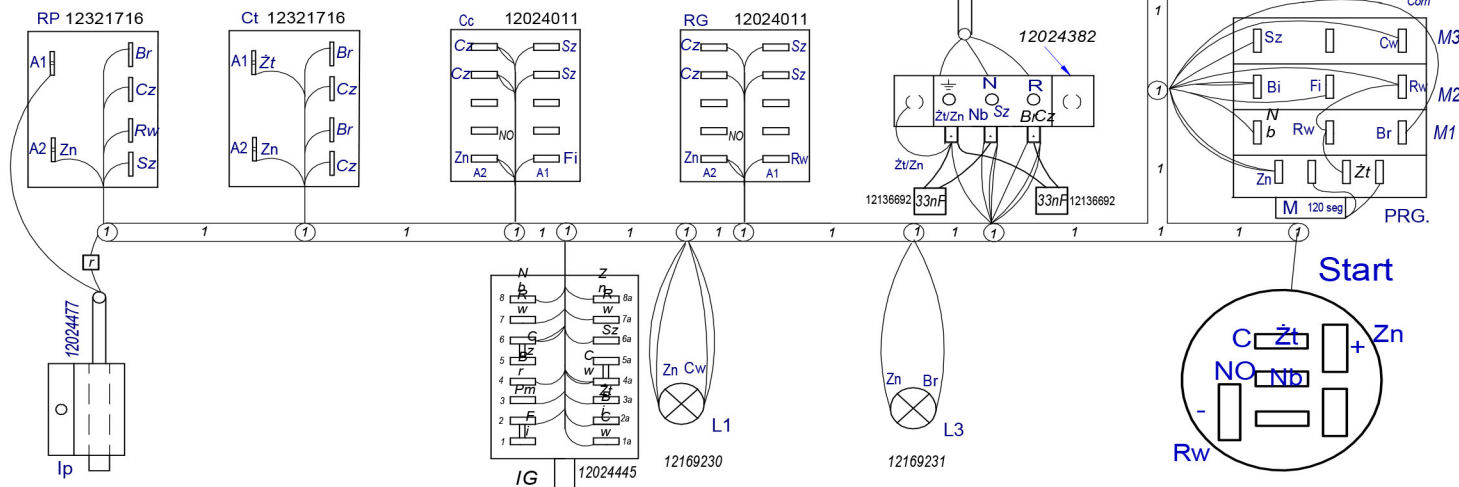